



3 Series

The industry choice for quality, speed of process and energy savings



The 3 Series is the Junair mid-range spraybooth which is designed and built to individual requirements, offering enhanced features to increase the quality of the paint finish.

Fully glazed doors improve vision into and out of the cabin. The LEVAC EX floor, an optional extra, delivers excellent downdraught airflow as well as eliminating the need for intrusive floor excavation.

- ➔ High Quality Construction
- ➔ HSE & FPA Fire Compliant
- ➔ Easy Change Filters
- ➔ LED Lighting Level Minimum 1000 Lux
- ➔ Full range of spraybooths options



Call us now on  01706 363 555 to discuss your requirements

3 Series Spraybooth Oven

The 3 Series is designed and manufactured in the UK using premium quality construction materials. Its white polyester paint finish on galvanised steel substrate offers excellent corrosion resistance and a light working environment whilst also providing an aesthetically pleasing modern and clean appearance. Wall and roof panels are sealed internally ensuring optimum cleanliness. A full width and full length balanced plenum is incorporated for improved air-movement within the booth. Filter media is quick and simple to change by just one operative. The 3 Series comes with fully glazed 2 leaf doors as standard, with a wide door opening, 2,652mm, for ease of loading and unloading whilst offering undisturbed views into and out of working areas.

Performance

- Designed for use with compliant coatings.
- Junair QADs* provide more consistent results than conventional spraybooth equipment. Typically reducing process times by up to 35%.
- Direct gas fired with fully modulating burner ensures fast temperature rise and accurate temperature profiling. Direct firing saves approximately 30% of fuel cost compared to indirect gas fired systems.
- Quiet in operation, 76-78dBa. Sound attenuation is an integral part of the air handling plant (conforms to HSE legislation).
- Direct drive centrifugal fans aluminium impellers are reliable and efficient with no drive belts to change. * QADs auxiliary air movement system option



UltraLux LED Lighting

- Provides excellent colour rendition and uniform lighting.
- Lighting level minimum 1,000 lux using angled white steel reflectors.
- UltraLux LED light fittings reduce the shadow areas within the cabin.
- Lights accessible from inside spraybooth for ease of maintenance.

Junair eSystem Control Panel

Easy to use Siemens PLC control System offering the user a straight forward method of operating the spraybooth. Siemens technology ensures you have the most reliable product possible. Option to upgrade to *iSystem3 touch screen control panel.



eSystem



* iSystem3

Energy Efficiency - Energy Efficient options include;

- QADs* auxiliary air movement system (up to 40% energy saving).
- FS Mode* - automatic recirculation for idle and flash off (saves a further 20%)
- Variable Speed Drives* (up to 70% energy saving when combined with the above)
- Eff3 energy efficient motors fitted as standard: a tax rebate may be claimed for these.

* Features incur an additional cost



* LEVAC EX floor - optional extra

Dimensions

- **Length** 7,000mm internal length as standard. Option for 8,000mm.
- **Width** 4,000mm internal.
- **Height** 2,500 internal height as standard. Option for 3,100mm or 3,600.

Air temperature

25°C above external ambient on spray cycle.

Floor

Central pit floor as standard. Option for full downdraught LEVAC EX or EVAC EX floor with pit.

LEVAC EX Floor requires no excavation and sits on customers own floor.

EVAC EX Floor 500mm deep fully extracted and gridded floor.

Filtration

- **Input Filter** 3,650mm wide by 6,000mm long. Resin applied. EU5.
- **Extract Filter** PolyMat EX longlife filter to promote a longer life for your spraybooth oven. PolyMat EX lasts longer than traditional duplex extract filters giving you longer between filter changes. The inner workings of the spraybooth are kept cleaner for longer, reducing build up of overspray inside the air handling plant, increasing the longevity of the spraybooth.



Air Handling Plant

- Floor standing or chest mounted. Internally accessed.
- Downdraught air movement, Ceiling input with floor extraction.
- Direct, fully modulating, gas fired burner—natural gas or LPG.



Air Handling Plant	12,000m ³ /h	20,000m ³ /h	25,000m ³ /h	30,000m ³ /h	35,000m ³ /h
Burner	100kW	170kW	212kW	260kW	300kW
Input & Extract fans	3.0kW	5.5kW	7.5kW	11kW	11kW
Electrics - 415v / 50Hz	20A	32A	45A	63A	63A
Input - Natural Gas	9.2m ³ /h	15.6m ³ /h	19.4m ³ /h	23.8m ³ /h	27.5m ³ /h
Input - LPG	14l/h	24l/h	30l/h	36l/h	42l/h
Gas Pressure	Minimum 20mbar - Maximum 50mbar				

Fan Motors - Input & Extract fans are IE2 or IE3—415V three phase high efficiency motors.

Warranty, service and support

- 3 year warranty available subject to service contract and terms and conditions.
- Skilled engineers provide national service support with maintenance divisions nationwide.
- Spare parts available ex stock.

Legislation – Designed manufactured and installed to meet the latest government legislation; EU machinery directive CE, COSHH, Environmental Protection Act, Health and Safety at Work Act, ATEX.

Front elevation - LEVAC EX Floor

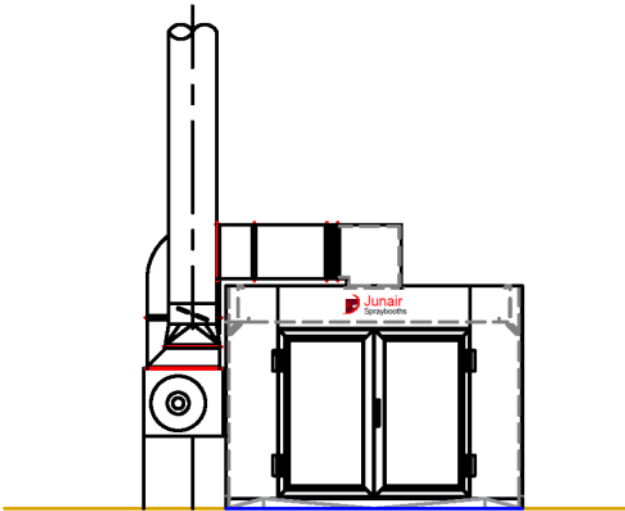

Front elevation - EVAC EX Floor

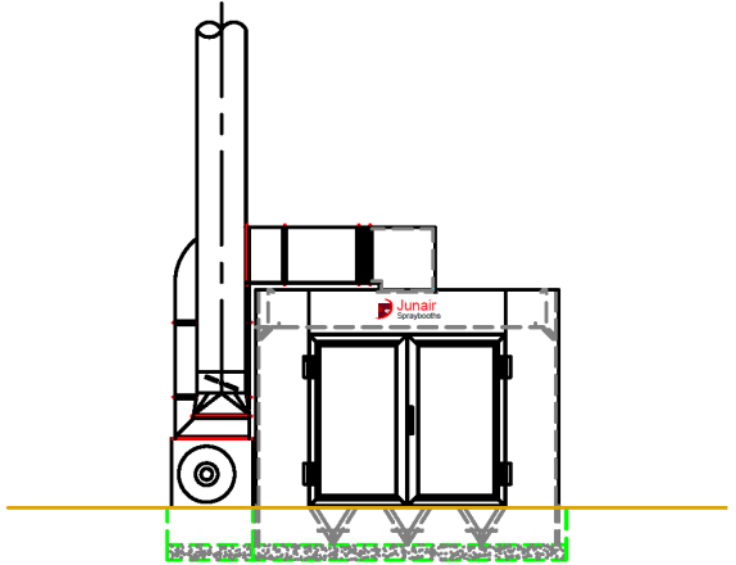

Side elevation - LEVAC EX Floor

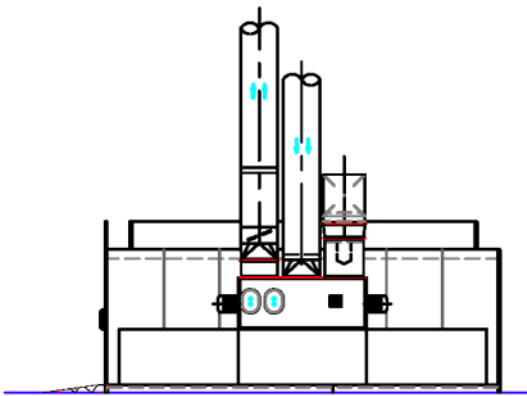

Side elevation - EVAC EX Floor

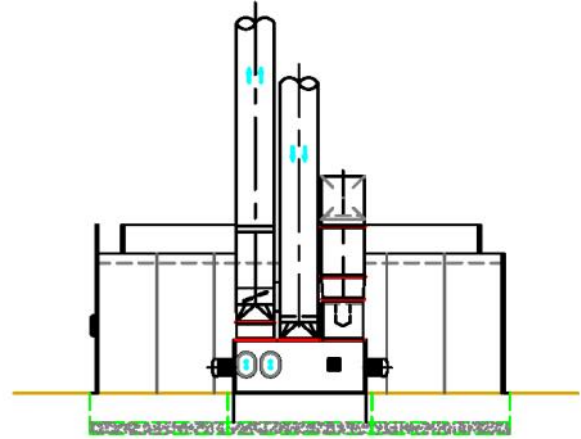

Plan View - LEVAC EX Floor

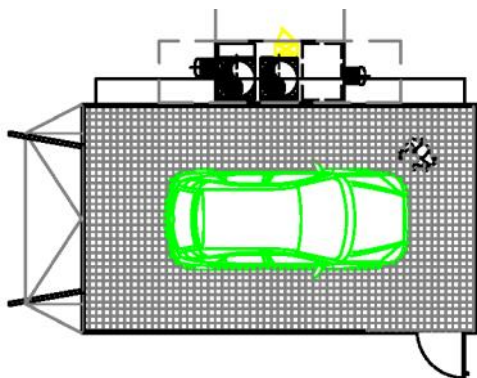

Plan view - EVAC EX Floor

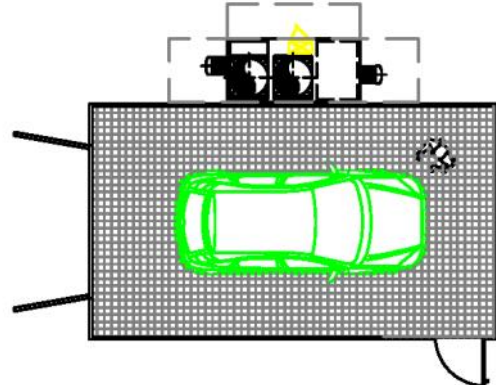

Call us now on  01706 363 555 to discuss your requirements